

PRODUCT DATA SHEET
SFP TRANSCEIVER
for SONET/SDH

HTR6518B Series

for Extended Temperature OC-48 IR-1 (up to 15km)



Features

- SONET OC-48 IR-1 (2488.32Mbit/s, 15km) , SDH STM-16(S-16.1) compliant.
- Fully comply with industry standard Small Form Factor Pluggable transceiver (Hot pluggable).
- High temperature operating (-5 to +85 deg-C at operating case temperature)
- Diagnostic monitor as enhanced function for SFP.
- AEL class 1 laser product per FDA/CDRH and EN60825-1 laser safety regulations.
- LC duplex receptacle.
- Built-in optical isolator in 1310nm DFB laser sub-assembly.
- Metal cover and inner shield for low EMI emission.
- Receiver return loss of higher than 27dB.
- SFP MSA compliant delatch mechanism and improved handling type (single or double bail type) delatch mechanism and improved ESD immunity type bail are available. ESD improved type has plastic under cover and hook to boost the ESD immunity when electrostatic discharge is applied to the bail.
- +3.3V single power supply.
- Low power consumption (0.5W(typ.)).

1. General

This document specifies the characteristics of the Small Form Factor Pluggable optical transceiver (Type:HTR6518B) with LC duplex receptacle for an OC-48 Intermediate Reach interfaces (IR-1, up to 15km). This transceiver applies single mode optical fiber -9/125.

2. Function

This transceiver is powered from a single +3.3V power supply and operated at data rate of 2488.32Mbit/s(NRZ). Optical output power is held constant by automatic power control over the specified operating temperature and voltage ranges.

The optical output is disabled by a TTL logic level input for that purpose. Tx Fault is provided to indicate the degradation of the laser diode. Loss Of Signal (LOS) output is provided to indicate the loss of an incoming optical signal. Tx Fault and LOS are open collector type outputs. The type of this transceiver is identified by Module Definition function using a built-in EEPROM with I²C interface.

As enhanced functions for SFP, internally measured transceiver temperature, internally measured supply voltage, laser bias current, laser optical output power and received optical power can be monitored by reading a built-in memory with I²C interface for that purpose. The interface pins for the monitor function are common with the Module Definition function.

Dimensions and pin assignment fully comply with MSA (Multi Source Agreement) for SFP (Small Form Factor Pluggable) optical transceiver.

3. Explanation of Part Number

HTR6518B	
Model Number	
Delatch mechanism	
Blank	SFP MSA compliant type
R	Single bail (lever) type
R2	Double bail (lever) type
R3	Single bail (lever) and plastic hook type
R4	Double bail (lever) and plastic hook type

4. Absolute Maximum Ratings

Stresses in excess of the ratings listed in Table 1 can cause permanent damage to the device and affect device reliability. Functional operation of the device is not implied at any condition in excess of those given in the operating specification.

Table 1. Absolute Maximum Ratings

Parameter	Symbol	Min.	Max.	Unit
Supply Voltage	V_{CC}	0	4.0	V
Data Input Voltage	V_{IN}	V_{EE}	$V_{CC}+0.3$	V
Receiver Optical Input Power	P_{in}	-	+3	dBm
Operating Case Temperature ^a	T_C	-5	85	deg-C
Storage Case Temperature	T_{stg}	-40	85	deg-C
Operating Relative Humidity (non-condensing)	H_A	5	85	%

a. Case temperature measurement point is shown below.

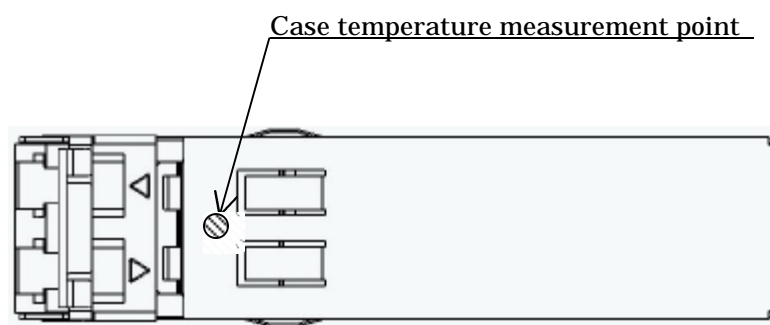

5. Optical and Electrical Characteristics of Transmitter Portion

Optical and electrical characteristics of transmitter portion are shown in Table 2. Unless otherwise stated, minimum and maximum values are specified over the operating ambient temperature, and humidity ranges, DC power supply voltage range, from beginning to end of life, using 2²³-1 pseudo random bit stream with a 50% duty factor.

The logic sense for the DATA input is such that a logic “1”(High) corresponds to the maximum level of an amplitude modulated light source (Light on), while a logic “0”(Low) corresponds to a minimum level of an amplitude modulated light source (Light off).

Table 2. Transmitter Optical and Electrical Characteristics

Parameter	Symbol	Min	Typ	Max	Unit
Optical Output Power	P _o	-5	-	0	dBm
Center Wavelength	λ	1260	-	1360	nm
Spectral Width(-20dB)	Δλ	-	-	1	nm
Sidemode suppress Ratio	SSR	30	-	-	dB
SONET Eye Mask	-	Compliant with GR253 spec.			-
Extinction Ratio	-	8.2	-	-	dB
DC Power Supply Voltage	V _{CC}	3.135	3.3	3.465	V
DC Power Supply Current	I _{CC}	-	-	140	mA
Data Input Voltage ^a				-	
Diff'l Input Swing	V _{ID SWING}	500	-	2400	mV _{p-p}
Diff'l Input Impedance	Z _{ID}	85	100	115	Ω
TX Fault Output Voltage: ^b					
Low	V _{OL}	0	-	0.8	V
High	V _{OH}	2.0	-	V _{CC}	V
Tx Disable Voltage	V _D	V _{CC} -1.3	-	V _{CC}	V
Tx Enable Voltage	V _{EN}	V _{EE}	-	V _{EE} +0.8	V

a. AC coupled and terminated by 100ohm resistor (differentially) inside the module.

b. Open collector output. It should be pulled up by 4.7k to 10k ohm resistor to V_{CC}.

6. Optical and Electrical Characteristics of Receiver Portion

Optical and electrical characteristics of receiver portion are shown in Table 3. Unless otherwise stated, minimum and maximum values are specified over the operating ambient temperature, and humidity ranges, DC power supply voltage range and wavelength range, from beginning to end of life, using a $2^{23}-1$ pseudo random bit stream with a 50% duty factor.

Table 3. Receiver Optical and Electrical Characteristics

Parameter	Symbol	Min	Typ	Max	Unit
Optical input Power (Average) ^a	P _{IN}	-18	-	0	dBm
Optic Path Penalty	P _O	-	-	1	dB
Receiver Reflectance	R _O	-	-	-27	dB
LOS Threshold:					
Decreasing Light Input	LOST _D	-35	-	-18.5	dBm
Increasing Light Input	LOST _I	-	-	-18	dBm
Hysteresis	LOST _H	0.5	-	6	dB
DC Power Supply Voltage	V _{CC}	3.135	-	3.465	V
DC Power Supply Current	I _{CC}	-	-	100	mA
Data Output Voltage ^b					
Diff'l Output Swing	V _{OD SWING}	640	800	1000	mV _{p-p}
Output Transition Time ^c	t _o	-	-	150	ps
LOS Output Voltage: ^d					
Low	V _{OL}	-	-	V _{EE} +0.4	V
High	V _{OH}	V _{CC} -0.9	-	-	V
LOS Response Time:					
Decreasing Light Input	LOSRT _D	-	-	100	μs
Increasing Light Input	LOSRT _I	-	-	100	μs

a. At a BER of 1×10^{-10} and an extinction ratio of 8.2dB

b. AC coupled inside the module

c. Between 20% and 80% (50% duty cycle)

d. Open collector output. It should be pulled up by 4.7k to 10k ohm resistor to V_{CC}.

7. Physical Design

The package outline of SFP MSA compliant delatch mechanism is shown in Figure 1.

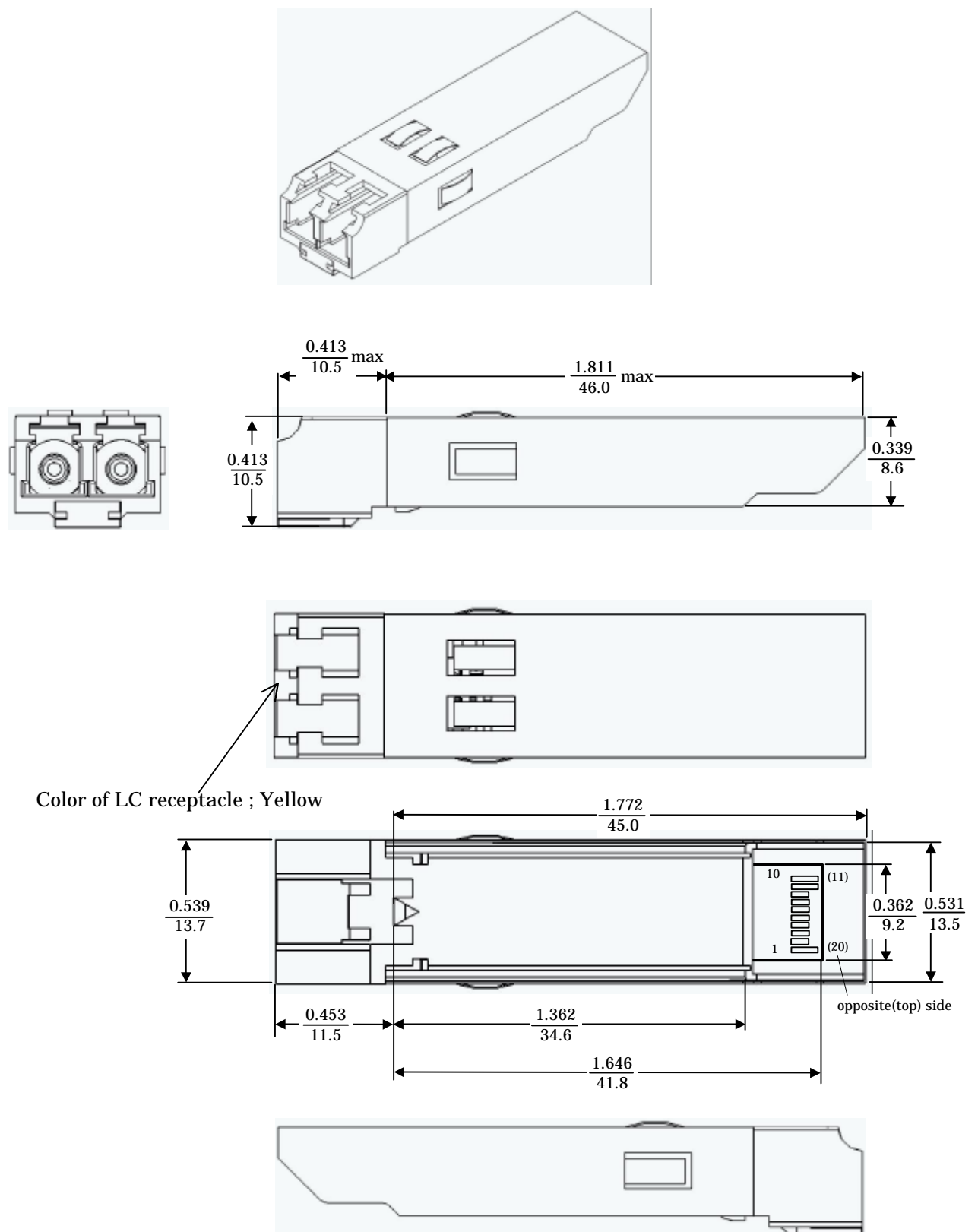

Unless otherwise stated, typical values are shown

unit: $\frac{\text{inch}}{\text{mm}}$

Figure 1. The package outline of SFP MSA compliant delatch mechanism

The package outline of bail (lever) delach mechanism type is shown in Figure 2.

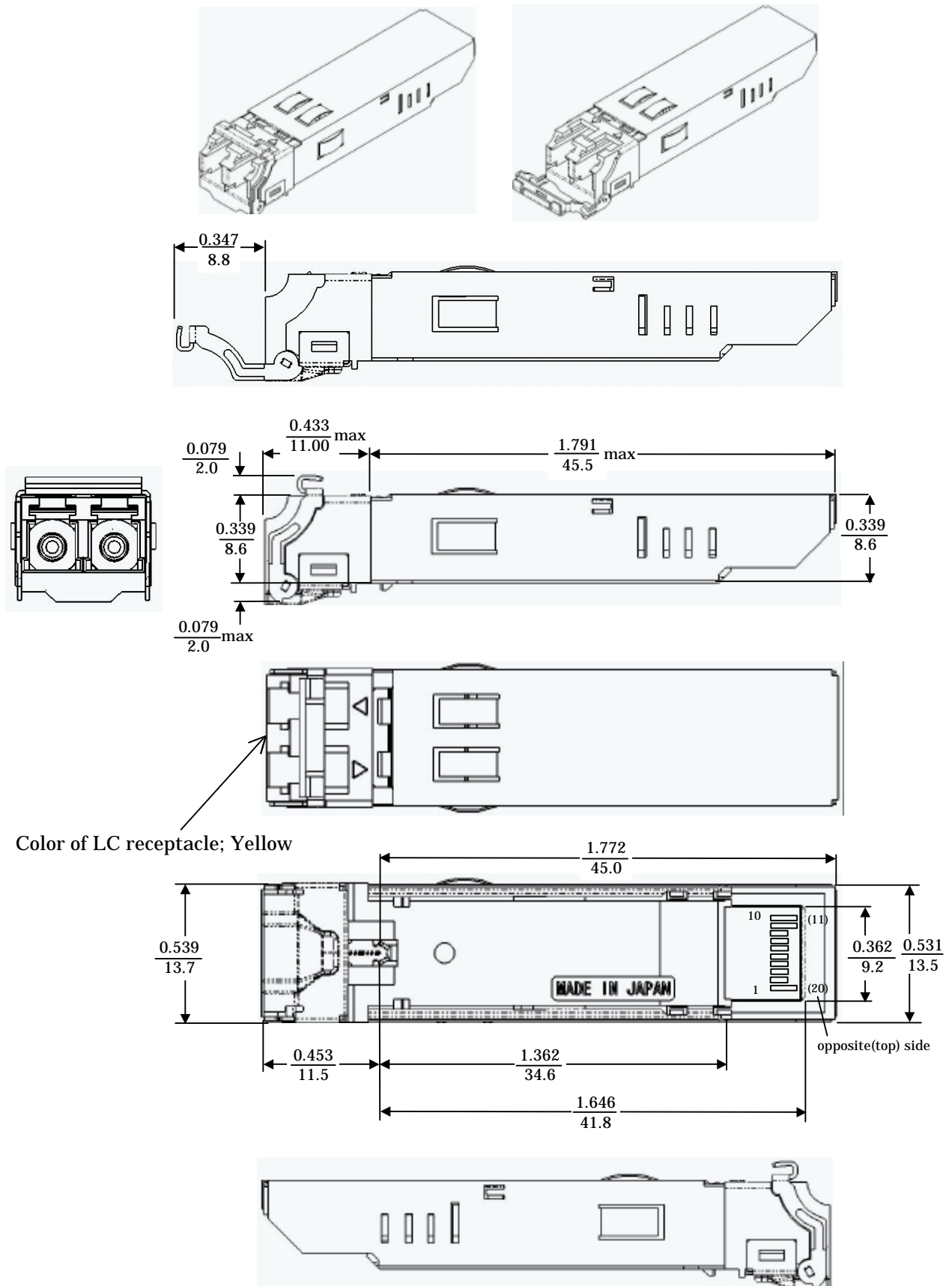

Unless otherwise stated, typical values are shown

Figure 2. The package outline of bail (lever) delach mechanism type

The package outline of double bail delach mechanism type is shown in Figure 3.

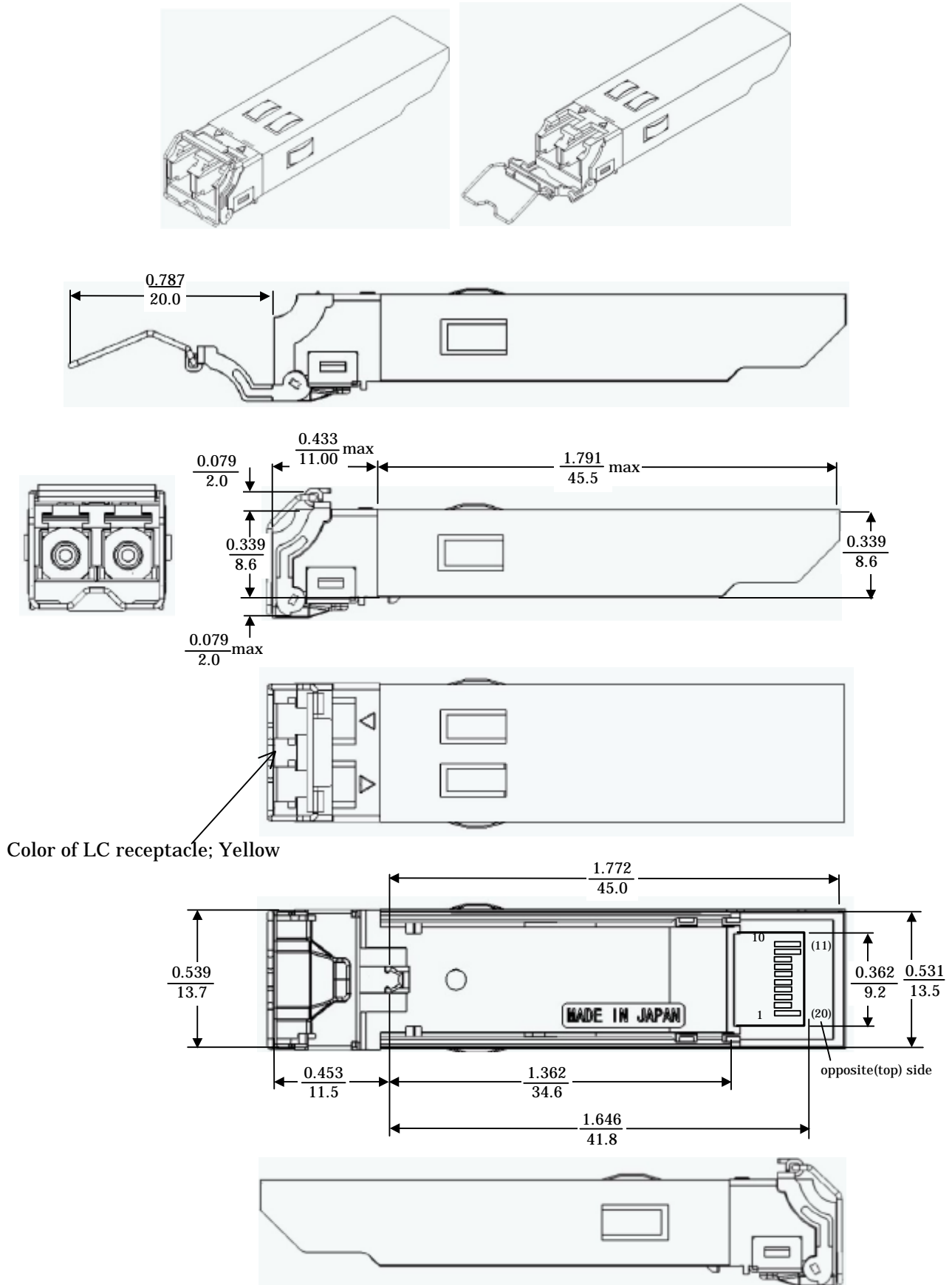
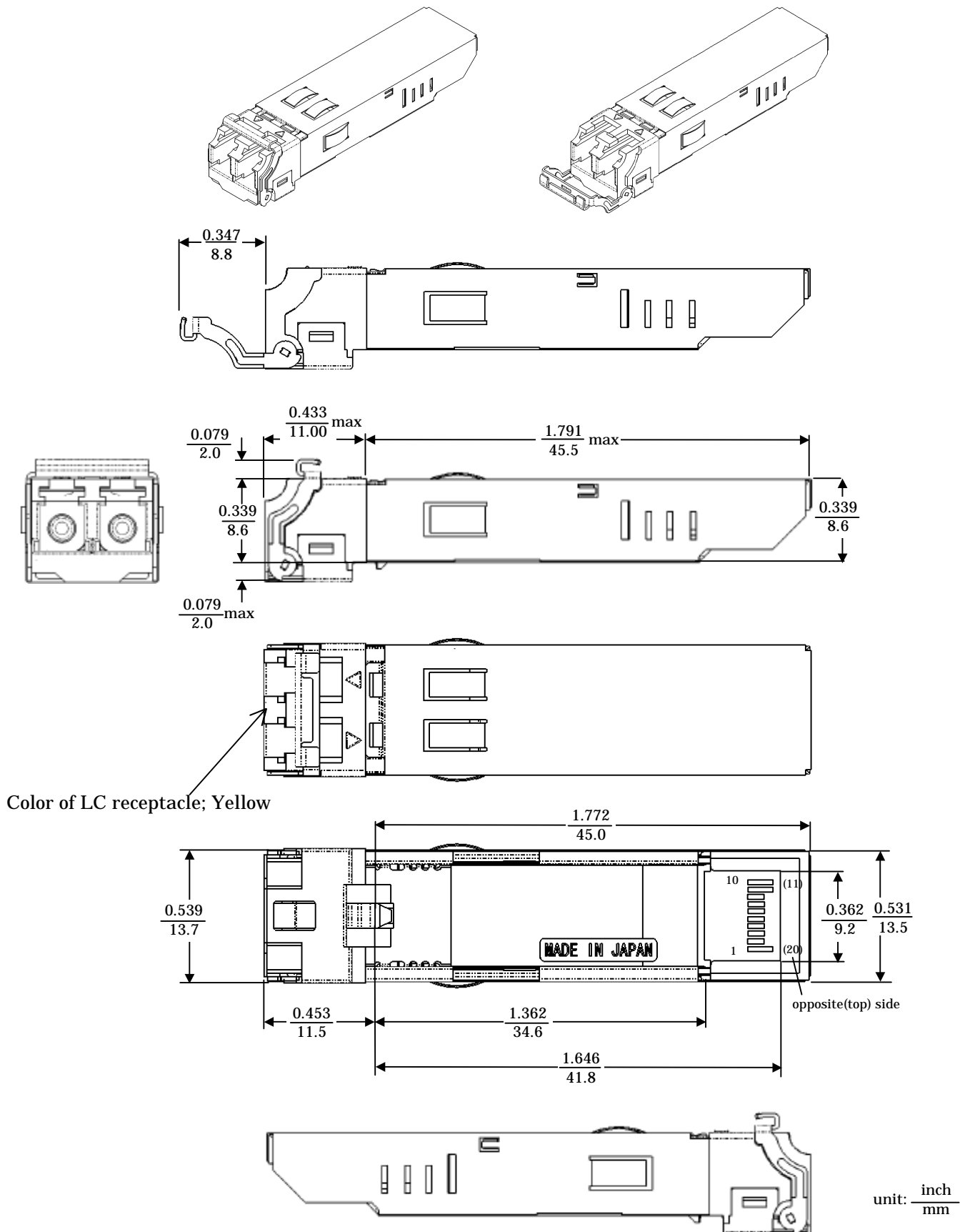

Figure 3. The package outline of double bail delach mechanism type

The package outline of ESD improved bail (lever) delach mechanism type is shown in Figure 4.



Unless otherwise stated, typical values are shown

Figure 4. The package outline of ESD mproved bail (lever) delach mechanism type

The package outline of ESD improved double bail delach mechanism type is shown in Figure 5.

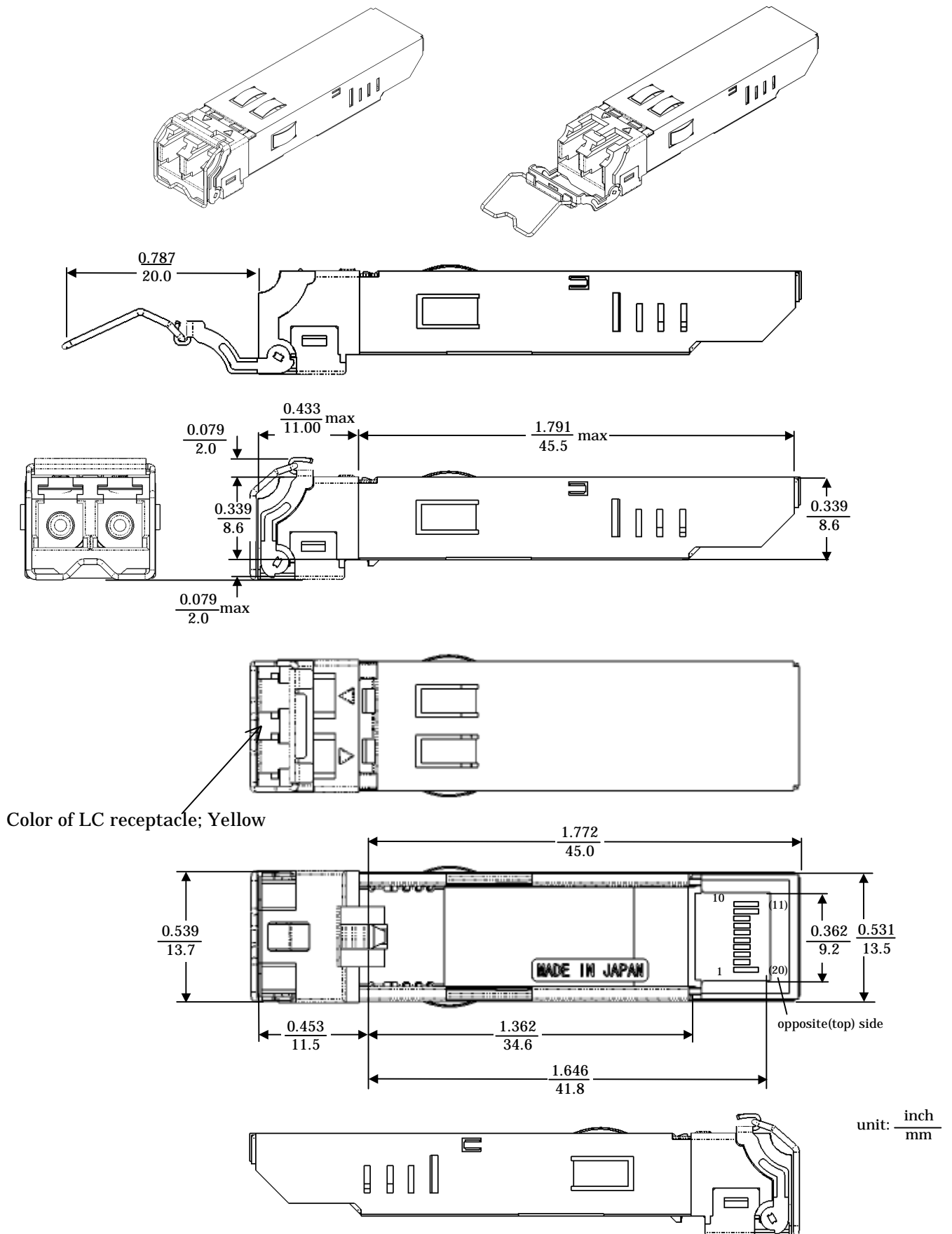

Unless otherwise stated, typical values are shown

Figure 5. The package outline of ESD improved double bail delach mechanism type

8. Label

Identification label is put on the top side of the transceiver. Sample is shown in Figure 6.

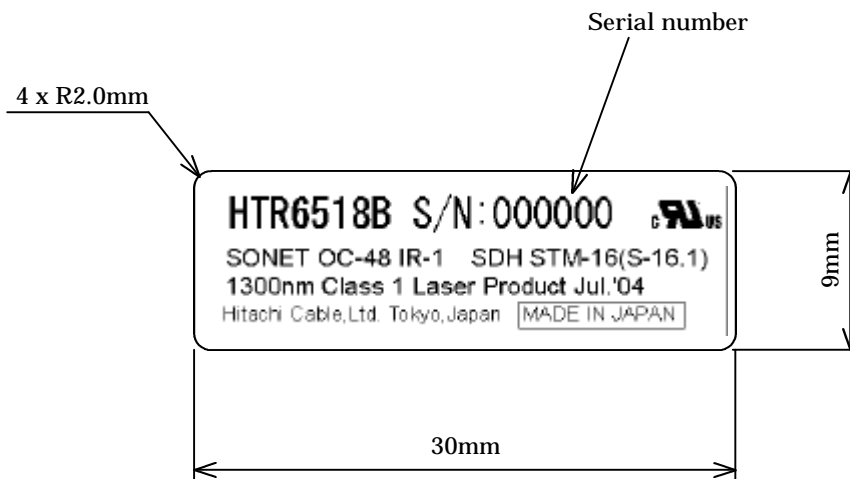

Figure 6. Identification label

9. PINOUT

Pinout is shown in Table 4.

Table 4. Pin Designations

Name	Symbol	Pin		Pin	Symbol	Name
Transmitter Ground	VeeT	20		1	VeeT	Transmitter Ground
Inv. Transmit Data In	TD-	19		2	Tx Fault	Transmitter Fault Indication
Transmit Data In	TD+	18		3	Tx Disable	Transmitter Disable
Transmitter Ground	VeeT	17		4	MOD_DEF(2)*	Module Definition 2
Transmitter Power	VccT	16		5	MOD_DEF(1)*	Module Definition 1
Receiver Power	VccR	15		6	MOD_DEF(0)*	Module Definition 0
Receiver Ground	VeeR	14		7	(Rate Select)	Unused function
Received Data Out	RD+	13		8	LOS	Loss of Signal
Inv. Received Data Out	RD-	12		9	VeeR	Receiver Ground
Received Ground	VeeR	11		10	VeeR	Receiver Ground

* Mod-Def 0,1,2 are the module definition pins. They should be pulled up with a 4.7K-10K Ω resistor on the host board.

Mod-Def 0 is grounded by the module to indicate that the module is present.

Mod-Def 1 is the clock line of two wire serial interface (I²C) for serial ID.

Mod-Def 2 is the data line of two wire serial interface (I²C) for serial ID.

For use of two wire serial interface (I²C), referring to Philips I²C bus specification or ATMEL AT24C01A/02/04 data sheet is recommended. Refer to URL below for more detail:

<http://www.semiconductors.philips.com/buses/i2c/facts/index.html> or,

<http://www.atmel.com/acrobat/doc0180.pdf>

10. Block Diagram and Recommended Circuit

Block diagram and recommended decoupling and termination for HTR6518B is illustrated in Figure 7. This recommendation will provide a good performance of the optical transceiver.

Host board layout, the design of SFP cage and SFP electrical connector should comply with the SFP MSA requirements.

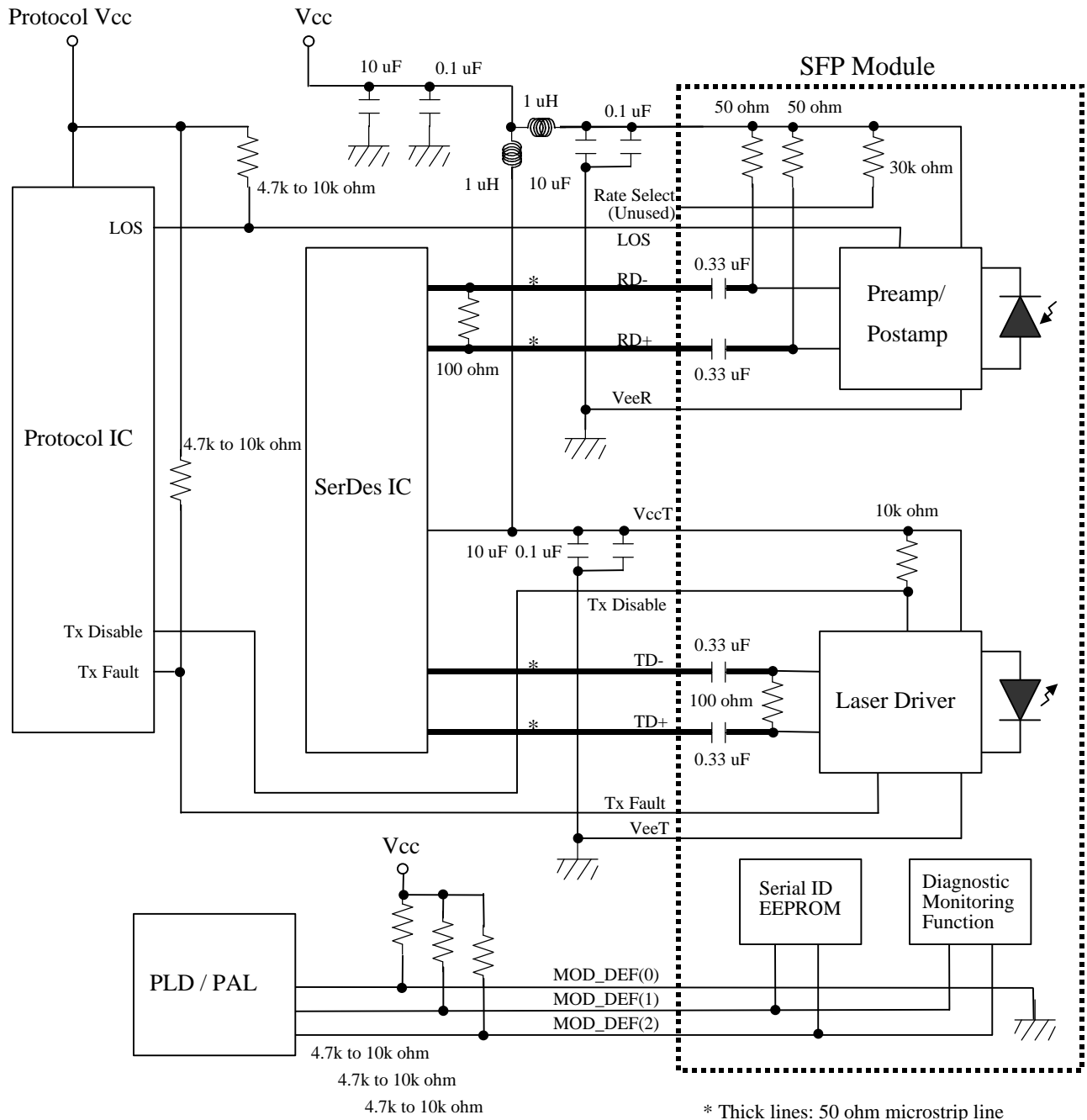

Figure 7. Block Diagram and Recommended Circuit

11. Serial identification

This transceiver features an EEPROM for Serial ID. Contents of the Serial ID are shown in Table 5.

Table 5. EEPROM Serial ID Memory Contents

Data Address	Field Size (Bytes)	Name of Field	Value(Hex)	Remark
BASE ID FIELDS				
0	1	Identifier	03	SFP
1	1	Ext.Identifier	04	
2	1	Connector	07	LC connector
3-10	8	Transceiver	00 12 00 00 00 00 00 00	Transceiver codes(OC-48 IR-1)
11	1	Encoding	03	NRZ
12	1	BR, Nominal	19	25(units of 100Mbits/sec)
13	1	Reserved	00	
14	1	Length(9u)-km	0F	15(units of km)
15	1	Length(9u)	96	150(units of 100m)
16	1	Length(50u)	00	Not supported
17	1	Length(62.5u)	00	Not supported
18	1	Length(Copper)	00	Not supported
19	1	Reserved	00	Not supported
20-35	16	Vendor name	48 69 74 61 63 68 69 20 43 61 62 6C 65 20 20 20	"Hitachi Cable"(ASCII)
36	1	Channel Spacing	00	
37-39	3	Vendor OUI	00 40 66	
40-55	16	Vendor PN	48 54 52 36 35 31 38 42 20 20 20 20 20 20 20 20	"HTR6518B"(ASCII) PN of SFP MSA compliant delatch type
			48 54 52 36 35 31 38 42 52 20 20 20 20 20 20 20	"HTR6518BR"(ASCII) PN of single bail delatch type
			48 54 52 36 35 31 38 42 52 32 20 20 20 20 20 20	"HTR6518BR2"(ASCII) PN of double bail delatch type
			48 54 52 36 35 31 38 42 52 33 20 20 20 20 20 20	"HTR6518BR3"(ASCII) PN of improved ESD immunity single bail
			48 54 52 36 35 31 38 42 52 34 20 20 20 20 20 20	"HTR6518BR4"(ASCII) PN of improved ESD immunity double bail
			20 20 20	(ASCII)
56-59	4	Vendor rev	20 20 20 20	(ASCII)
60-61	2	Wavelength	05 1E	1310nm(16-bit unsigned integer)
62	1	DWDM Wavelength Fraction	00	
63	1	CC_BASE	Check sum(Variable)	Check code for Base ID Fields
EXTENDED ID FIELDS				
64-65	2	Options	00 1A	Loss of Signal, TX_FAULT, TX_DISABLE implemented
66	1	BR, max	01	1(units of %)
67	1	BR, min	01	1(units of %)
68-83	16	Vendor SN	30 30 30 31 32 33 20 20 20 20 20 20 20 20 20 20 (*1)	Serial number of transceiver(ASCII) (*1 Sample of number is "000123")
84-91	8	Date code	30 34 31 31 31 36 30 30 (*2)	Manufacturing date code(ASCII) (*2 Sample of date is "04111600")
92	1	Diagnostic Monitoring Type	58(01011000 in binary)	Digital Diagnostic monitoring implemented. Calibration type is "External Calibration", Rx power measurement type is "Average Power".
93	1	Enhanced options	80(10000000 in binary)	Alarm/Warning flags implemented for all monitored quantities.
94	1	SFF-8472 Compliance	01	Includes functionality described in Rev.9.0 SFF-8472.
95	1	CC_EXT	Check sum(Variable)	Check code for Extended ID Fields
VENDOR SPECIFIC ID FIELDS				
96-255	160	Reserved	Unused	Filled by zero

12.Enhanced Functions

Enhanced functions interface uses the 2 wire address 1010001X (0xA2). Memory contents of enhanced functions are shown in Table 6.1.

Table 6.1 Memory Contents / 2 wire address 1010001X (0xA2)

Data Address	Field Size (Bytes)	Name	Remark
CONSTANTS FIELDS			
00-01	2	Temperature High Alarm	Set to 92 deg-C
02-03	2	Temperature Low Alarm	Set to -23 deg-C
04-05	2	Temperature High Warning	Set to 90 deg-C
06-07	2	Temperature Low Warning	Set to -13 deg-C
08-09	2	Vcc High Alarm	Set to 3.6 V
10-11	2	Vcc Low Alarm	Set to 3.0 V
12-13	2	Vcc High Warning	Set to 3.5 V
14-15	2	Vcc Low Warning	Set to 3.1 V
16-17	2	Laser Bias High Alarm	Various at each device
18-19	2	Laser Bias Low Alarm	Various at each device
20-21	2	Laser Bias High Warning	Various at each device
22-23	2	Laser Bias Low Warning	Various at each device
24-25	2	Tx Power High Alarm	Manufacture measurement plus 3 dB
26-27	2	Tx Power Low Alarm	Manufacture measurement minus 3dB
28-29	2	Tx Power High Warning	Manufacture measurement plus 2 dB
30-31	2	Tx Power Low Warning	Manufacture measurement minus 2dB
32-33	2	Rx Power High Alarm	Maximum input power plus 1 dB
34-35	2	Rx Power Low Alarm	Minimum input power minus 2 dB
36-37	2	Rx Power High Warning	Maximum input power plus 0.5 dB
38-39	2	Rx Power Low Warning	Minimum input power minus 1 dB
40-55	16	Reserved	All bytes set to 0x00
56-59	4	Rx Power Calibration Data R ₄	Single precision floating-point numbers (various values at each device for incompatibility with "internal calibration")
60-63	4	Rx Power Calibration Data R ₃	
64-67	4	Rx Power Calibration Data R ₂	
68-71	4	Rx Power Calibration Data R ₁	
72-75	4	Rx Power Calibration Data R ₀	
76-77	2	Laser Bias Calibration Data B ₁	Unsigned fixed-point number (set to 1) *
78-79	2	Laser Bias Calibration Data B ₀	16-bit signed 2's complement number (set to 0) *
80-81	2	Tx Power Calibration Data P ₁	Unsigned fixed-point number (set to 1) *
82-83	2	Tx Power Calibration Data P ₀	16-bit signed 2's complement number (set to 0) *
84-85	2	Temp. Calibration Data T ₁	Unsigned fixed-point number (set to 1) *
86-87	2	Temp. Calibration Data T ₀	16-bit signed 2's complement number (set to 0) *
88-89	2	Vcc Calibration Data V ₁	Unsigned fixed-point number (set to 1) *
90-91	2	Vcc Calibration Data V ₀	16-bit signed 2's complement number (set to 0) *
92-94	3	Reserved	All bytes set to 0x00
95	1	Checksum	Low order 8 bits of the sum of byte 0-94.
VARIABLES FIELDS			
96-97	2	Measured Temperature	Raw 16-bit A/D value (see Table 6.2)
98-99	2	Measured Vcc	Raw 16-bit A/D value (see Table 6.2)
100-101	2	Measured Laser Bias	Raw 16-bit A/D value (see Table 6.2)
102-103	2	Measured Tx Power	Raw 16-bit A/D value (see Table 6.2)
104-105	2	Measured Rx Power	Raw 16-bit A/D value (see Table 6.2)
106-109	4	Reserved	All bytes set to 0x00
110	1	Logic States	See Table 6.4
111	1	AD Updated	See Table 6.4
112-119	8	Alarm and Warning Flags	See Table 6.5
VENDOR SPECIFIC FIELDS			
120-127	4	Vendor Specific	Do not access in order to operate normally
128-255	128		See Table 6.6

* Slopes B₁=P₁=T₁=V₁=1, intercepts B₀=P₀=T₀=V₀=0, for compatibility with "internal calibration".

The measured values located at bytes 96-105 (in the 2 wire address 0xA2) are raw A/D values (16-bit integers) of transceiver temperature, supply voltage, laser bias current, laser optical output power and received power. All the measured values are "externally calibrated" over specified temperature and supply voltage, and then it is necessary to convert raw A/D values to real world units using the external calibration constants located at bytes 56-91 (0xA2) by the manner as shown in Table 6.2.

Table 6.2 Measured Values / 2 wire address 1010001X (0xA2)

Byte	Name	Description
96	Temp MSB	Internally measured transceiver temperature, T_{AD} (16-bit signed 2's complement integer). Actual temperature, T , is given by, $T=T_1*T_{AD}+T_0$, where T_1 and T_0 are calibration data at bytes 84-87. The result is 16-bit signed 2's complement value with LSB equal to 1/256 deg-C (see Table 6.3a), yielding a total range of -128 to +128 deg-C. Accuracy of result is better than +/-3 deg-C.
97	Temp LSB	
98	Vcc MSB	Internally measured supply voltage, V_{AD} (16-bit unsigned integer). Actual voltage, V , is given by, $V=V_1*V_{AD}+V_0$, where V_1 and V_0 are calibration data at bytes 88-91. The result is 16-bit unsigned value with LSB equal to 100 μ V (see Table 6.3b), yielding a total range of 0 to 6.55 V. Accuracy of result is better than +/-50 mV. Note that transmitter supply voltage measured since VccT and VccR are isolated.
99	Vcc LSB	
100	Laser Bias MSB	Measured Laser bias current, B_{AD} (16-bit unsigned integer). Actual current, B , is given by, $B=B_1*B_{AD}+B_0$, where B_1 and B_0 are calibration data at bytes 76-79. The result is 16-bit unsigned value with LSB equal to 2 μ A (see Table 6.3b), yielding a total range of 0 to 131 mA. Accuracy of result is better than +/-10%.
101	Laser Bias LSB	
102	Tx Power MSB	Measured Tx power, P_{AD} (16-bit unsigned integer). Actual power, P , is given by, $P=P_1*P_{AD}+P_0$, where P_1 and P_0 are calibration data at bytes 82-85. The result is 16-bit unsigned value with LSB equal to 0.1 μ W (see Table 6.3b), yielding a total range of 0 to 6.55 mW. Accuracy is better than +/-2dBm.
103	Tx Power LSB	
104	Rx Power MSB	Measured Rx power, R_{AD} (16-bit unsigned integer). Actual power, R , is given by $R = R_4*R_{AD}^4 + R_3*R_{AD}^3 + R_2*R_{AD}^2 + R_1*R_{AD} + R_0,$ where R_4 , R_3 , R_2 , R_1 and R_0 are calibration data at bytes 56-75. The result is 16-bit unsigned value with LSB equal to 0.1 μ W (see Table 6.3b), yielding a total range of 0 to 6.55 mW. Accuracy is better than +/-3dBm from -20dBm to 0dBm optical input power.
105	Rx Power LSB	

The formats of values shown in Table 6.2 are interpreted below. The result of temperature, T , and the calibration intercepts, T_0 , V_0 , B_0 , and P_0 , are 16-bit signed 2's complement numbers with corresponding LSB (e.g. laser bias, B_0 , has 2 μ A LSB) as shown in Table 6.3a. The result of Vcc, V , laser bias, B , Tx power, P , and Rx power, R are 16-bit unsigned numbers with corresponding LSB (e.g. laser bias, B , has 2 μ A LSB) as shown in Table 6.3b. The calibration slopes, T_1 , V_1 , B_1 , and P_1 , are unsigned fixed-point numbers as shown in Table 6.3c. The calibration coefficients, R_4 , R_3 , R_2 , R_1 , and R_0 , are IEEE-754 single precision floating-point numbers as shown in Table 6.3d.

Table 6.3a 16-Bit Signed 2's Complement Number (MSB at low address)

	Bit 7	Bit 6	Bit 5	Bit 4	Bit 3	Bit 2	Bit 1	Bit 0
MSB	SIGN	2^{14}	2^{13}	2^{12}	2^{11}	2^{10}	2^9	2^8
LSB	2^7	2^6	2^5	2^4	2^3	2^2	2^1	2^0

Table 6.3b 16-bit Unsigned Number (MSB at low address)

	Bit 7	Bit 6	Bit 5	Bit 4	Bit 3	Bit 2	Bit 1	Bit 0
MSB	2^{15}	2^{14}	2^{13}	2^{12}	2^{11}	2^{10}	2^9	2^8
LSB	2^7	2^6	2^5	2^4	2^3	2^2	2^1	2^0

Table 6.3c Unsigned Fixed-Point Number (MSB at low address)

	Bit 7	Bit 6	Bit 5	Bit 4	Bit 3	Bit 2	Bit 1	Bit 0
MSB	2^7	2^6	2^5	2^4	2^3	2^2	2^1	2^0
LSB	2^{-1}	2^{-2}	2^{-3}	2^{-4}	2^{-5}	2^{-6}	2^{-7}	2^{-8}

Table 6.3d IEEE-754 Single Precision Floating-Point Number (MSB at low address)

	Bit 7	Bit 6	Bit 5	Bit 4	Bit 3	Bit 2	Bit 1	Bit 0
MSB	SIGN	EXPONENT						
	EXPONENT	MANTISSA						
LSB	MANTISSA							
	MANTISSA							

This transceiver is implemented two optional status bits, "Logic States" at byte 110 (0xA2) and "A/D Updated" at byte 111 (0xA2) as shown in Table 6.4. "A/D updated" status bits allows the user to verify if an update from the analog-digital conversion has occurred to the measured values, temperature, Vcc, laser bias, Tx power and Rx power. The user writes the byte to 0x00. Once a conversion is complete for a given value, its bit will change to '1'.

Table 6.4 Optional Status Bits / 2 wire address 1010001X (0xA2)

Byte	Bit	Name	Description
110	7	Tx Disable State	Optional digital state of the Tx Disable input pin.
110	6	Soft Tx Disable Control	Not supported (set to 0).
110	5	Reserved	Set to 0.
110	4	Rx Rate Select State	Not supported (set to 1).
110	3	Soft Rate Select Control	Not supported (set to 0).
110	2	Tx Fault	Optional digital state of the Tx Fault output pin.
110	1	LOS	Optional digital state of the LOS output pin.
110	0	Power on Logic	Bit will be 0 when the analog monitoring is active.
111	7	Temp A/D Valid	Indicates A/D value in Bytes 96/97 is valid.
111	6	Vcc A/D Valid	Indicates A/D value in Bytes 98/99 is valid.
111	5	Laser Bias A/D Valid	Indicates A/D value in Bytes 100/101 is valid.
111	4	Tx Power A/D Valid	Indicates A/D value in Bytes 102/103 is valid.
111	3	Rx Power A/D Valid	Indicates A/D value in Bytes 104/105 is valid.
111	2	Reserved	Set to 0.
111	1	Reserved	Set to 0.
111	0	Reserved	Set to 0.

Each of the measured values has a corresponding high alarm, low alarm, high warning and low warning threshold level at location 00-39 (0xA2) written as the data format of a corresponding value shown in Table 6.2. Alarm and warning flags at bytes 112-119 (0xA2) are defined as follows,

- (1) Alarm flags indicate conditions likely to result (or have resulted) in link failure and cause for immediate action,
- (2) Warning flags indicate conditions outside the guaranteed operating specification of transceiver but not necessarily causes of immediate link failures.

Table 6.5 Alarm and Warning Flags / 2 wire address 1010001X (0xA2)

Byte	Bit(s)	Name	Description
112	7	Temp. High Alarm	Set when temp. monitor value exceeds high alarm level.
112	6	Temp. Low Alarm	Set when temp. monitor value is below low alarm level.
112	5	Vcc High Alarm	Set when Vcc monitor value exceeds high alarm level.
112	4	Vcc Low Alarm	Set when Vcc monitor value is below low alarm level.
112	3	Laser Bias High Alarm	Set when laser bias monitor value exceeds high alarm level.
112	2	Laser Bias Low Alarm	Set when laser bias monitor value is below low alarm level.
112	1	Tx Power High Alarm	Set when Tx power monitor value exceeds high alarm level.
112	0	Tx Power Low Alarm	Set when Tx power monitor value is below low alarm level.
113	7	Rx Power High Alarm	Set when Rx power monitor value exceeds high alarm level.
113	6	Rx Power Low Alarm	Set when Rx power monitor value is below low alarm level.
113	5-0	Reserved	All bits set to 0.
114	7-0	Reserved	All bits set to 0.
115	7-0	Reserved	All bits set to 0.
116	7	Temp. High Warning	Set when temp. monitor value exceeds high warning level.
116	6	Temp. Low Warning	Set when temp. monitor value is below low warning level.
116	5	Vcc High Warning	Set when Vcc monitor value exceeds high warning level.
116	4	Vcc Low Warning	Set when Vcc monitor value is below low warning level.
116	3	Laser Bias High Warning	Set when laser bias monitor value exceeds high warning level.
116	2	Laser Bias Low Warning	Set when laser bias monitor value is below low warning level.
116	1	Tx Power High Warning	Set when Tx power monitor value exceeds high warning level.
116	0	Tx Power Low Warning	Set when Tx power monitor value is below low warning level.
117	7	Rx Power High Warning	Set when Rx power monitor value exceeds high warning level.
117	6	Rx Power Low Warning	Set when Rx power monitor value is below low warning level.
117	5-0	Reserved	All bits set to 0.
117	7-0	Reserved	All bits set to 0.
117	7-0	Reserved	All bits set to 0.

Table 6.6 SFP information / 2 wire address 1010001X (0xA2)

Data Address	Field Size (Bytes)	Name of Field	Value(Hex)	Remark
USER EEPROM FIELDS				
128-255	128	Reserved		Filled by ZERO

13. Inspection

Main inspection items are as follows:

- (1) Appearance
- (2) Dimensions
- (3) Optical output power
- (4) Optical waveform
- (5) Optical input power
 - a) Average Sensitivity
 - b) Loss of Signal / Decreasing Light Input
 - c) Loss of Signal / Increasing Light Input
- (6) Power supply current

14. Packing

The optical transceiver shall be packed in hard carton box(es) for shipping.

15. Cautions

- (1) Do not stare into the optical output port although this product has been designed to meet the class 1 laser regulation.
- (2) The package of the transceiver is subject to cracking or dissolving in case of contact with the chemicals listed below.(2.B) We recommend to use fluids in the cleaning process which are proved not to affect the transceiver case.(2.A) Pay attention in the solder flux and during the cleaning process. We recommend to carefully check the appropriateness of the cleaning fluid in advance.
 - 2.A. methyl alcohol, ethyl alcohol, butyl alcohol, isopropyl alcohol, hexane, cyclohexane, naphtha, tetrachloroethylene, propylene glycol,
 - 2.B. Do not use : Chemicals which may crack or dissolve
trichloroethylene, trichloroethane, benzen, methyl ethyl ketone, chloroform, toluene, acetone, phenol, ethyl acetate, methylene di chloride, isophtalic acid dimethyl ester
- (3) The Optical connectors should be thoroughly cleaned before the insertion into the optical receptacles of the transceiver in order to avoid contamination inside.
The contamination may cause serious degradation in the transmission performance. Compressed air and a cleaning stick ("CLETOP, stick type" for LC/MU connector supplied by NTT international is recommended) should be used in case the receptacle gets in contact with dusty or dirty optical connectors.
- (4) The transceiver cannot in any case be washed with water, even if the endcap is attached to the LC receptacle.
- (5) The endcap attached to the LC receptacle of the transceiver can be re-used. This is the only part washable with water.

= MEMO =

= Notice =

- All information contained in this document is subject to change without notice.
- No responsibility is assumed by Hitachi Cable, Ltd. For its use nor for any infringements of third parties, which may result from its use.
- Products described in this document are not intended for use in implantation or other life support applications where malfunction may result in injury or death to persons.
- Customer must contact Hitachi Cable, Ltd. to obtain the latest specification to verify, before placing any order, that the information contained herein is current.

 **Hitachi Cable, Ltd.** <http://www.hitachi-cable.co.jp/>

Hitachi Cable America, Inc. <http://www.hitachi-cable.com/>